

Metis M309 / M316 / M318

Highly Advance 1-Color Pyrometer

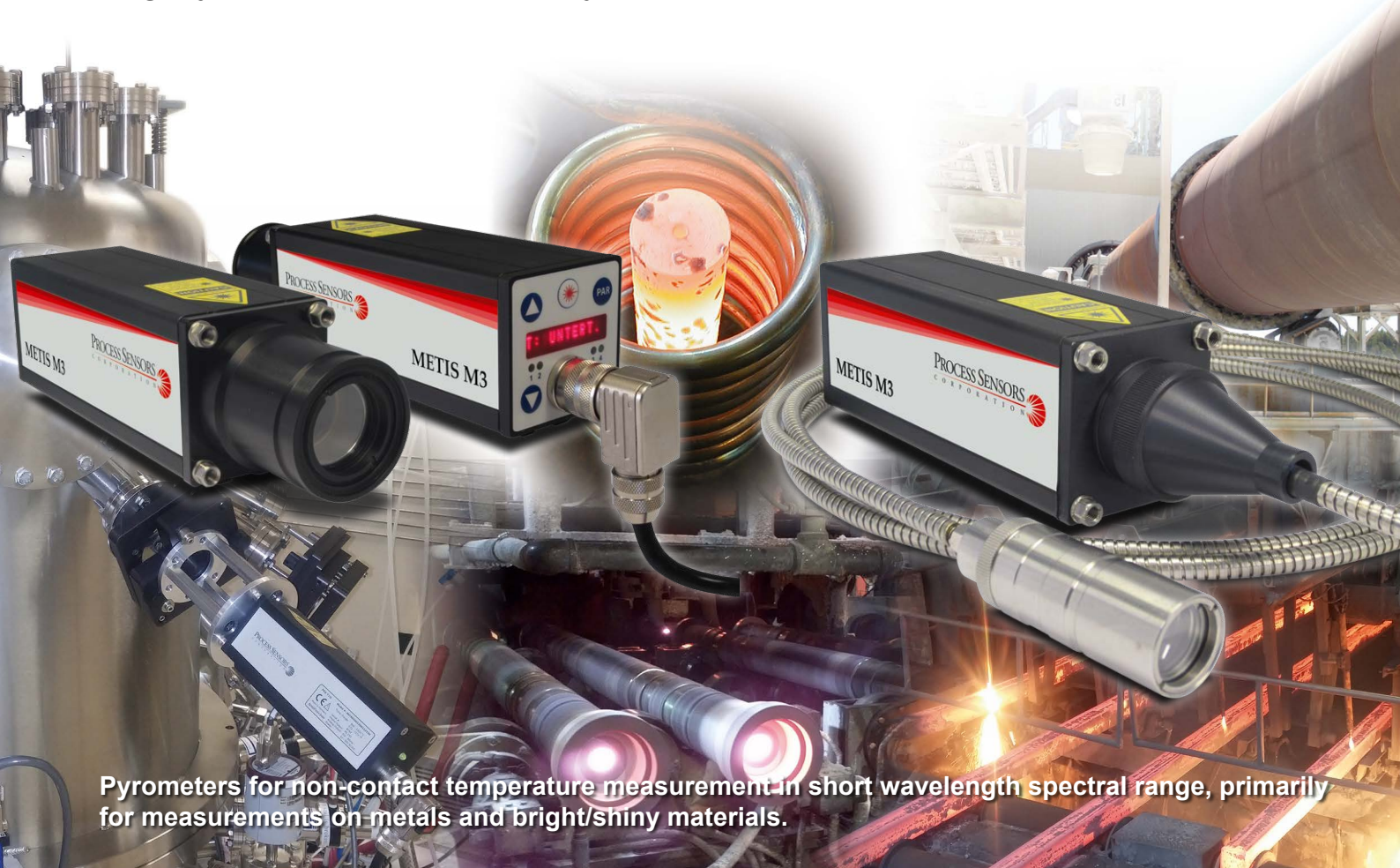

Pyrometers for non-contact temperature measurement in short wavelength spectral range, primarily for measurements on metals and bright/shiny materials.

APPLICATIONS

- Induction heating
- Steel/metals
- Metal pour streams
- Kilns
- Vacuum furnaces
- Welding
- Ceramics
- Composites
- Sintering
- Nuclear
- Research and development.

FEATURES

- Highest accuracy and repeatability, even at high temperatures and up to 80°C (176°F) without cooling
- Wide temperature ranges between 100°C and 3300°C (212°F and 5972°F)
- Fully digital and very fast with response time <1 ms
- Different optics with extremely small spot sizes from 0.3 mm can be selected
- 10-digit matrix display for temperature and IR sensor parameters
- Push button device configuration or via software
- 2 high resolution 16 bit analog 0/4 to 20mA outputs
- 3 versatile configurable inputs or outputs
- Analogue input for external setpoint or emissivity setting
- Laser targeting, color video or thru-lens sighting
- Serial interfaces RS232 and RS485 (switchable)
- Optional fieldbus connection: Profinet or Profibus

Technical Data

Model	M309	M316	M318
Temperature ranges	550 – 1400°C 600 – 1600°C 650 – 1800°C 750 – 2500°C 900 – 3000°C 1000 – 3300°C	250 – 1300°C 350 – 1800°C 400 – 2500°C 500 – 3300°C	100 – 700°C 180 – 1300°C
Temp. sub ranges	Any temperature sub-range adjustable within the temperature range (minimum span 50°C)		
Spectral range	0.7–1.1 µm	1.45–1.8 µm	1.65–2.1 µm
Detector	Silicon	InGaAs	InGaAs
Response time t_{90}	< 1 ms (with dynamical adaptation at low signal levels), adjustable up to 10 s		
Exposure time	< 0.5 ms		
Uncertainty ($\epsilon = 1$, $t_{90} = 1$ s, $T_A = 23^\circ\text{C}$)	Full-scale temp. up to 2500°C: 0.25% of reading in °C+1K Full-scale temp. above 2500°C: 0.5% of reading in °C		0.4% of reading in °C + 1 K or 2°C (the higher value is valid)
Repeatability ($\epsilon = 1$, $t_{90} = 1$ s, $T_A = 23^\circ\text{C}$)	0.1% of reading in °C + 1 K		0.2% of reading in °C + 1 K or 1.6°C (the higher value is valid)
Temperature coefficient (deviations from 23°C)	From 10 to 60°C: 0.02%/K From 0 to 10°C and 60 to 80°C: 0.04%/K		
Emissivity ϵ	0.050–1.200 (corresponds 5–120% in 0.1% steps)		
Transmission	0.050–1.000 (corresponds 5–100% in 0.1% steps)		
Fill factor spot size	0.050–1.000 (corresponds 5–100% in 0.1% steps)		
Analog output signal	2 configurable analog outputs 0 or 4–20 mA, max. load: 500 Ω Resolution 0.0015% of the adjusted temperature (16 Bit). Outputs can be set individually, inside or outside the measuring range.		
Serial interface	RS232 (max. 115 kBd) or RS485 (max. 921 kBd), switchable. Resolution 0.1°C or 0.1°F		
3 configurable Inputs / outputs	<ul style="list-style-type: none"> ■ Digital inputs (max. 3 inputs, protected against reverse polarity): laser targeting light on/off, clearing of peak picker, load pyrometer configuration, trigger input for start / stop of measured value recording. ■ Digital outputs (max. 3 outputs, max. 50 mA, protected against short circuit): limit switch, exceeding the beginning of temperature range (for material recognition), device ready after self-test, device over-temperature, signal strength too low. ■ Analog input (0–20 mA, protected against reverse polarity and incorrect connection): analog emissivity adjustment 		
Peak picker	Automatic hold mode or manual time settings to clear (reset)		
Display	10-digit LED display (5 mm high) for temperature or settings of IR sensor parameters Resolution 0.1°C or 0.1°F		
Parameter settings	Push buttons on the device, serial interface, PC software <i>SensorTools</i> or via self-compiled communication program: Emissivity, transmission, fill factor, temperature sub range, settings for peak picker, device address, baud rate, response time, selecting analog outputs 0/4–20 mA, interface RS232/RS485 (selection on the device only), °C/°F, language (English / German), measuring distance with motorized focus optics.		
Power requirement	24 V DC (18–30 V DC), max. 6 VA; protected against reverse polarity		
Isolation	Voltage supply, analog and digital output are galvanically isolated from each other		
Sightings (optional)	<ul style="list-style-type: none"> ■ Thru-the-lens sighting with adjustable attenuation filter for eye protection of bright targets ■ Laser targeting light (red, $\lambda=650$ nm, $P < 1$ mW, class II to IEC 60825-1) ■ High dynamic color CCD camera, field of view: ca. 14% x 10% of measuring distance output signal: FBAS signal ca. 1 V_{pp}, 75 Ω, CCIR, NTSC / PAL switchable Resolution: NTSC: 720 x 480 pixel; PAL: 720 x 576 pixel 		
Optics (optional)	Manual focusable or optional motorized focus or fixed focus optics		
Ambient temperature	0 to 80°C, (M18: 0 to 60°C) storage: -20 to 85°C; with camera module: 0 to 60°C Fiber optic version: focusable lens assembly: -20 to 250°C (-4 to 482°F)		
Relative humidity	No condensing conditions		
Housing / protection class	Aluminum, IP65 to DIN 40 050 with connector		
Weight	650 g (1 lb. 6.9 oz.)		
CE label	According to EU directives for electromagnetic immunity		

Reference Numbers

Metis M309 Specify with temperature range, sighting method and optics

Metis M316 Specify with temperature range, sighting method and optics

Metis M318 Specify with temperature range, sighting method and optics

Note: *SensorTools* software is included in scope of delivery,
Connection cables are not included in scope of delivery and have to be ordered separately.

Power Up and Measure Temperature

In principle the M3 series only requires connection to a power supply to start a measurement.

Metis M3 pyrometers are stand alone, self contained IR thermometers with direct outputs for easy integration in nearly all application environments.

The short-wave spectral ranges of the various models are specially designed for accurate temperature measurements of metals and other bright, reflective materials.

The models M309, M316 and M318 differ in their spectral ranges and associated in their ranges.

The material to be measured largely determines which spectral range of the pyrometer should be selected. For metal measurements, the shortest possible spectral range for a precise measurement is advantageous. Due to technical reasons the beginning of a temperature range may be limited, to a higher starting temperature therefore a model must be selected with a slightly higher spectral range, e.g. longer wavelength.

Features

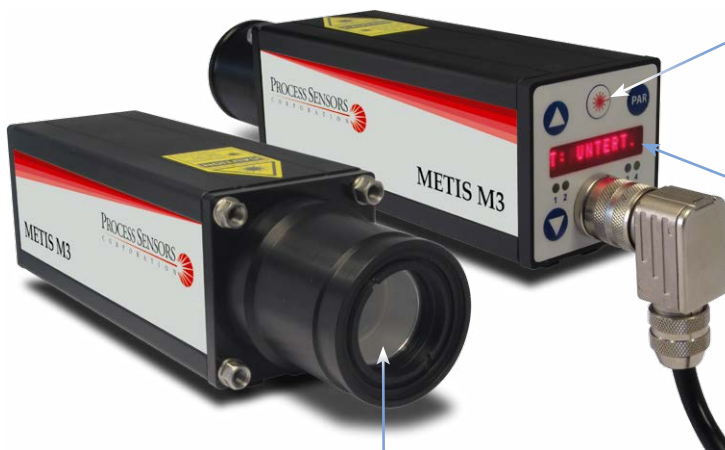

Proven Sighting:

- More precise laser target marking
- Enhanced view finder
- New high dynamic color camera module

Clear Device Operation:

- Large, bright 10 digit display
- All settings directly on the device
- Display of active alarm limit outputs
- Simple setting of the measuring distance with motor focus

Fast, Accurate Outputs:

- Serial high-speed interface up to 921 kBaud
- 2 high resolution 16 bit analog 0/4 to 20mA outputs

A Variety of Models:

- Motorized focus optics
- Optics with manual adjustment of focus
- Fixed focus optics for smallest spot sizes
- Fiber optic version with small optical heads

Harsh Environmental Conditions:

- M309 and M316 with an advanced ambient temperature up to 80°C
- Fiber optic models up to 250°C (lens and fiber optic cable)

Sighting Method Selection

Sighting is used to pinpoint the location of the measured target.

- **Devices with integrated optics:** Thru-lens view finder, laser targeting light or color camera module
- **Devices with fiber optics:** Laser targeting light

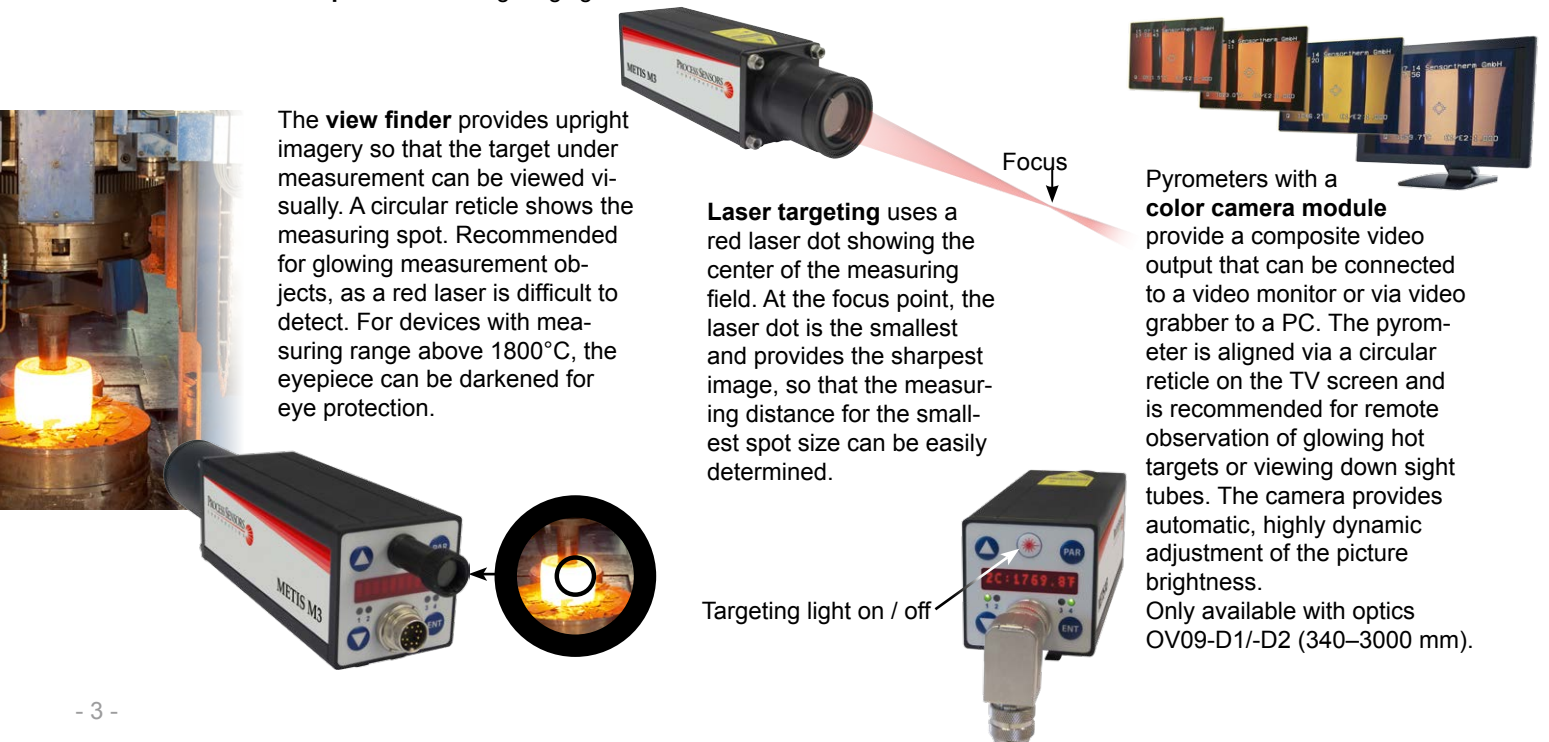

The **view finder** provides upright imagery so that the target under measurement can be viewed visually. A circular reticle shows the measuring spot. Recommended for glowing measurement objects, as a red laser is difficult to detect. For devices with measuring range above 1800°C, the eyepiece can be darkened for eye protection.

Laser targeting uses a red laser dot showing the center of the measuring field. At the focus point, the laser dot is the smallest and provides the sharpest image, so that the measuring distance for the smallest spot size can be easily determined.

Pyrometers with a **color camera module** provide a composite video output that can be connected to a video monitor or via video grabber to a PC. The pyrometer is aligned via a circular reticle on the TV screen and is recommended for remote observation of glowing hot targets or viewing down sight tubes. The camera provides automatic, highly dynamic adjustment of the picture brightness. Only available with optics OV09-D1/-D2 (340–3000 mm).

Targeting light on / off

Intelligent Installation Possibilities

Serial Interface RS232 or RS485 (Selectable)

Via serial interface, the pyrometer communicates with other digital devices such as a PLC, computer with free *SensorTools* software or a self-written communication software program. Measured values can be recorded and device parameters can be set directly on the device, via *SensorTools* software or serial interface RS232 or RS485.

- RS232 for short distances to the PC. Transfer rates of max. 115 kB
- RS485 for long distance connection. Max. of 921 kB, use in bus configuration.

An interface converter RS232 or RS485 to USB (accessory) allows for easy connection to a PC.

2 Analog Outputs

Each of the high-resolution analog outputs can be used for independent devices with 0/4-20 mA inputs, e.g. to connect additional temperature displays or other devices.

By “scalable” it is meant that the temperature range assigned to the analog outputs can be adapted to the specific application, allowing reduction or expansion of the range as needed when integrating the sensor into an existing system.

3 Configurable Inputs / Outputs

3 pyrometer connectors are available as digital input, digital output or analog input:

- Each **digital output** switches a low voltage output active or inactive (NC or NO, adjustable) with several selectable states (Rear panel LEDs indicate the switching state):
 - Limit switch for decreasing or exceeding a certain temperature threshold
 - Material detection (exceeding the beginning of temperature range)
 - Device state (device is ready for operation)
 - Over temperature, if the maximum allowed device temperature is exceeded
 - Signal strength is too low (dirty window alarm)
- Each **digital input** can be connected to an external contact closure and configured for a function:
 - Laser targeting light on and off
 - Manually delete (reset) of maximum value storage
 - Start / stop recording of measured values via the *SensorTools* software
 - Up to 7 pyrometer configurations can be saved and retrieved
- Using the **analog input** (available soon and to install via firmware update) a current can be fed for
 - Analog specification of the emissivity

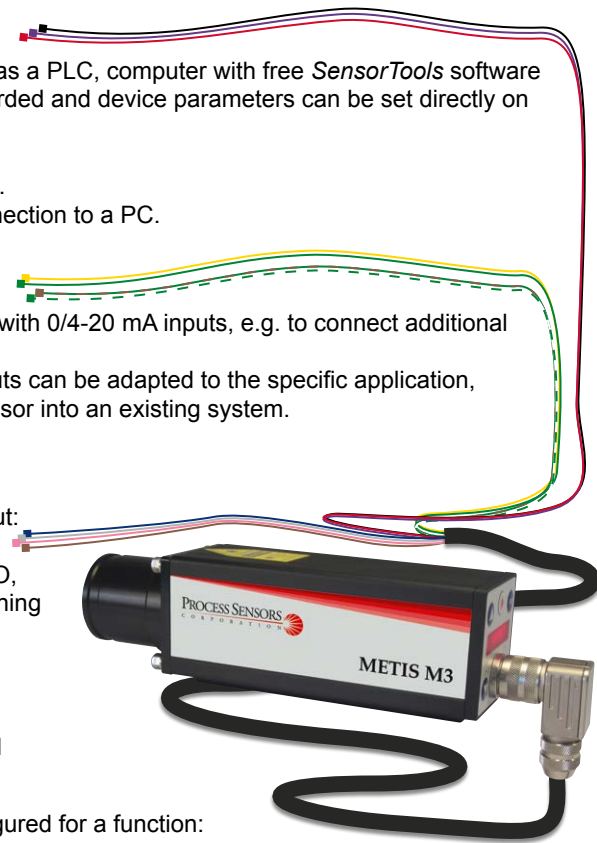

Ambient Temperature

M309 and M316 with laser targeting light or view finder are designed for ambient temperatures up to 80°C with a very low temperature coefficient. Thus, many new applications can be entered and solved without external cooling equipment.

Material Properties

The entry options for material settings have been simplified:

- **Emissivity:** Each material has a max. emissivity of 1.00 which can be set, an adjustment up to 1.20 can be used. The emissivity adjustment above 1.00 allows for temperature corrections due to higher background reflection.
- **Transmittance:** For measurements through windows signal losses occur by transmission of the window. This value is included with each window and can be entered easily.
- **Fill factor measurement field:** Measuring on cold background, the measurement object can be smaller than the spot size. At this point you can enter how many percent the pyrometer's spot size is filled.

Maximum Value Storage (Peak Picker)

The maximum value storage is a useful feature when the measured object appears only briefly in the pyrometer's field of view, or to capture peak temperatures while measuring a series of objects. The hottest value of the measured object is stored and disregards temperature valleys, e.g. steel surfaces with scale in hot rolling mill application. The maximum value can be reset automatically or manually or by a selectable clear time.

Fieldbus Systems

Optional pyrometer control can be done with

- Profinet or Profibus

Device Designs / Optics

The following tables show the optical data of the different device types. For reliable measurement the measurement object should be at least as large as the spot size.

Values in the optics tables illustrate the focused measuring distances and respective spot sizes. The spot size diameter for distances not given in the table can be interpolated.

The pyrometer can be used at distances other than its' focal distance, however the spot size is generally larger and therefore the target size must be larger.

Focusable optics (manual or motorized focus) can be continuously adjusted within the minimum and maximum specified measurement distance, providing the smallest possible spot size diameter at that focus distance.

Fixed focus optics are factory-set to a certain measurement distance reaching there the smallest possible spot size. The robust and precise design provides minimal axial deviations between mechanical and optical axis. This alignment is maintained even the device is rotated, useful in measurements through long sighting tubes.

The pyrometer must be properly aligned to the measurement object to detect the temperature correctly. In the focus point of the lens (focal distance) the spot size diameter is smallest. Measurements out of the focus distance are also possible (in front of or behind the focus distance) to determine the average temperature of a bigger spot.

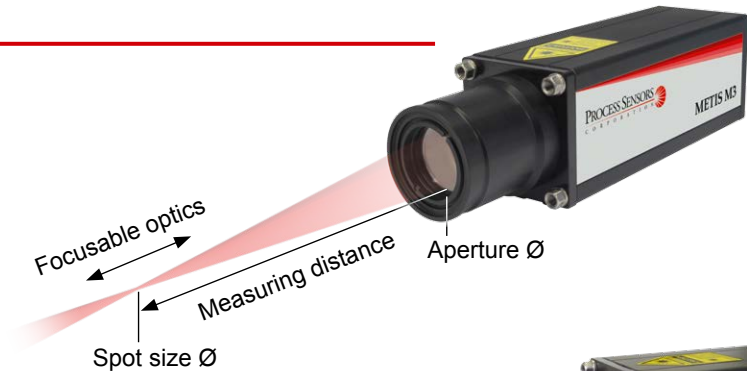

Focusable Optics (manually adjusted or motorized focus) with laser targeting light or view finder

Optics	Measuring distance a [mm]	Spot size M [mm]		Aperture Ø D [mm]
		M309 (all ranges) M316 (all ranges) M318 (180–1300°C)	M318 (100–700°C)	
OM09-A0	130 mm	0.3 mm	0.6 mm	16 mm (FSC<1400°C) 8 mm (FSC>1400°C)
	160 mm	0.4 mm	0.8 mm	
	200 mm	0.7 mm	1.4 mm	
OM09-B0	190 mm	0.6 mm	1.2 mm	16 mm (FSC<1400°C) 8 mm (FSC>1400°C)
	300 mm	0.8 mm	1.6 mm	
	420 mm	1.2 mm	2.4 mm	
OM09-C0	340 mm	0.8 mm	1.6 mm	16 mm (FSC<1400°C) 8 mm (FSC>1400°C)
	1000 mm	2 mm	4 mm	
	4000 mm	13 mm	26 mm	

Manual Focus

1. Turn counterclockwise
2. Pull / push in
3. Lock turn clockwise

Motor focus

- Via push buttons
- Via PC software

Focusable Optics (manually adjusted or motorized focus) with Color Camera Module

Optics	Measuring distance a [mm]	Spot size M [mm]	Aperture Ø D [mm]
M309: OV09-D1	340 mm	0.9 mm	16 mm (FSC<1400°C) 8 mm (FSC>1400°C)
M316/18: OV09-D2	1000 mm	2.8 mm	
	3000 mm	8.8 mm	

Fixed Focus Optics

with laser targeting light or view finder

Optics	Measuring distance a [mm]	Aperture Ø D [mm]
OM89	Fixed focus optics for smallest spot sizes and long measuring distances available on request. Distance ratio up to 900:1 (tube lengths 89 and 160 mm)	27 mm
OM160		27 mm

Focusable Fiber Optics (standard 25 mm outside diameter or miniature 12 mm) with laser targeting light

Optics	Measuring distance a [mm]	Spot size M [mm]	Aperture Ø D [mm]
Standard: OL25-G0	75 mm	0.5 mm	18 mm
	130 mm	0.65 mm	
	180 mm	0.7 mm	
Standard: OL25-H0	170 mm	0.75 mm	18 mm
	2000 mm	9 mm	
	4500 mm	22 mm	
Miniature: OL12-A0	100 mm	1 mm	7 mm
	350 mm	3.7 mm	
	600 mm	7 mm	
		Fiber Ø 0.2 mm	Fiber Ø 0.4 mm

FSC = Full scale temperature



Model Selection Table - Metis M309 / M316 / M318

A	B	C	D	E	F	G	H	M	N	P	L
M3xx	- xxxx	- xxxx	- x	- x	- x	- xx	- x	- x	- x	- x	- x

A	Model, detector, spectral range: M309 = Silicon, 0.7 – 1.1 μm M316 = InGaAs, 1.45 – 1.8 μm M318 = ext. InGaAs, 1.65 – 2.1 μm
B	Zero scale temperature: e.g. 0650 = 650°C
C	Full scale temperature: e.g. 1800 = 1800°C
D	Sighting method: 1 = Laser targeting 2 = View finder 4 = Color camera module
E	Serial Interface: 5 = Switchable RS485 / RS232
F	Optics: 1 = Fixed focus 2 = Focusable optics manual 3 = Fiber \varnothing 0.2 mm (refer to brochure) 4 = Fiber \varnothing 0.4 mm (refer to brochure) 8 = Focusable optics motorized B = Stainless steel sensor head heavy design for 0.2 mm fiber with OL/OQ25 C = Stainless steel sensor head heavy design for 0.4 mm fiber with OL/OQ25
G	Response time: 13 = 1 ms, adjustable to 10 s
H	Version: 0 = Standard 4 = PID controller (12 pin connector) 5 = 17 pin connector, 4 digital inputs, 2 digital outputs, PID controller, no display, no push button
M	Display: 4 = With, standard, not with 17 pin connector 0 = Without, only with 17 pin connector
N	Analog output: 2 = Two analog outputs, standard
P	Digital input / output: 3 = 3x Standard 4 = 4x only with 17 pin connector
L	Optics: A, B, C, D, G or H (Refer to product brochure)

Example: M309-0650-1800-1-5-2-13-0-4-2-3-A

This model refers to: Model M309, temperature range of 650-1800°C, laser targeting, RS232 & RS485 communication, manual focus optics, 1 ms response time, std. version sensor, onboard temperature display, two 0/4-20 mA outputs, 3 digital inputs/outputs, optics type A.

Software *SensorTools*

- Measurement display
- Measured value recording
- Processing the results
- Display devices inside temperature
- Changing pyrometer parameters

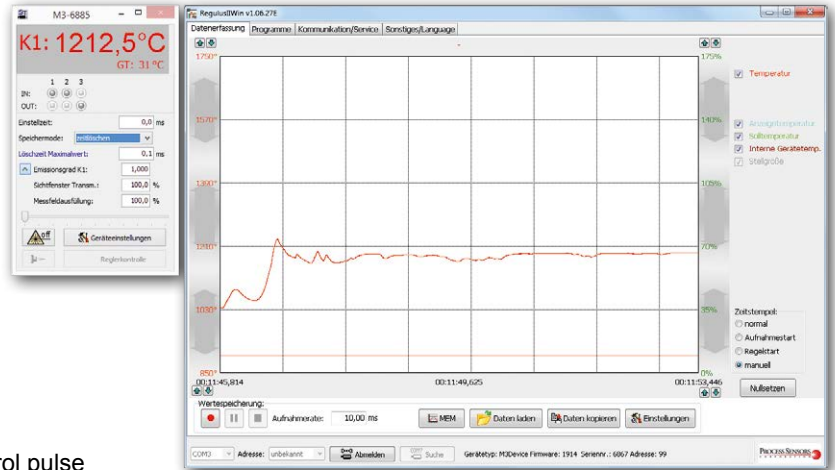

Program functions:

- Change pyrometer parameters
- Playback of recorded data
- Adapted graphics mode to computer performance
- Export measured values in csv files
- Record interval setting for acceptable data size.
- Back time recording of measured values after control pulse
- Laser targeting light switching on and off / configuring the camera display
- External start and stop of the recording measured values (via control input on the pyrometer)
- Create a service file with settings for remote diagnostics

Recommended Accessories

HA20	Ball and socket swivel mount for sensor alignment
HA10	Mounting bracket
HA14 / HA15	Adjustable mounting bracket for fiber optics OQ25 / OQ12
KG10	Aluminum water cooling housing
KG20	Aluminum cooling plate
BL10 / BL11	Air purge for devices with motor focus / manually focusable optics
BL13 / BL14	Air purge for fiber optics OQ12 / OQ25
AL11 / AL43	Connection cable, 14-wire (available in 5 m steps) with right angle connector / straight connector
AU11 / AU43	Connection cable, 14-wire, interface converter RS232<->USB with right angle connector / straight connector
AV11 / AV43	Connection cable, 14-wire, interface converter RS485<->USB with right angle connector / straight connector
AK50	Connection cable for camera module (Limosa-plug <-> Cinch-plug, available in 5 m steps)
IF0000	LED digital indicator for remote adjustment of IR sensor parameters
950-004	Power supply 24 V DC
950-060A-LCD	Plug & Play enclosure, with power supply and interface for setup parameters



Dimensions

Manual focusable optics

Motorized focus optics
Fixed focus optics

Fiber optic devices,
focusable optics

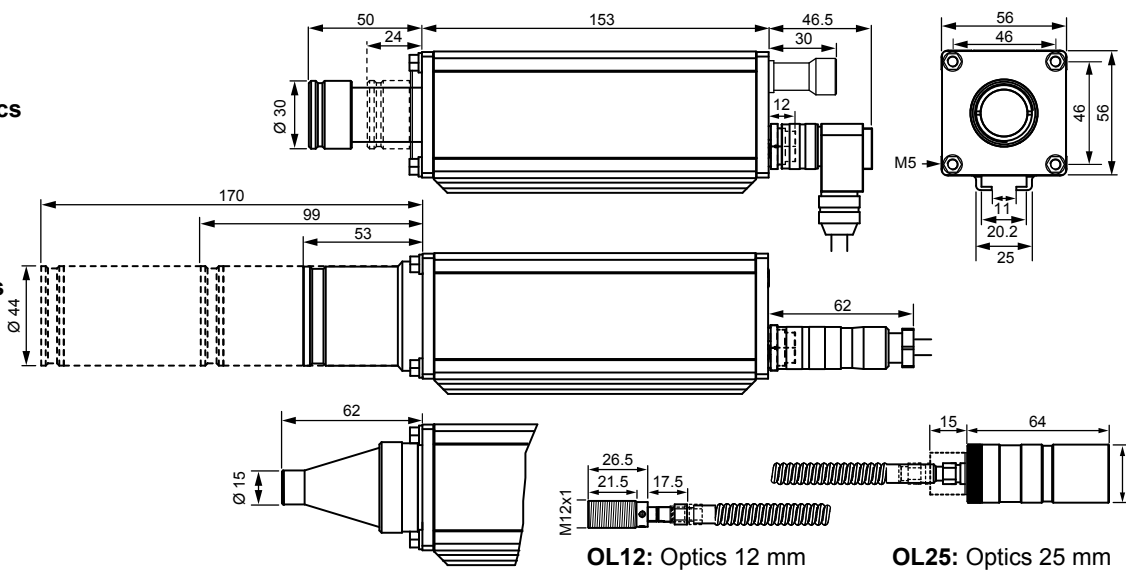

Process Sensors reserves the right to make changes in scope of technical progress or further developments.

Datasheet_Metis_M309_M316_M318 (Dec. 03, 2014)

PROCESS SENSORS CORPORATION

IR Temp. Sales Office: 787 Susquehanna Avenue, Franklin Lakes, NJ USA • Tel: 201-485-8773 • Fax: 201-485-8770

Corporate Headquarters: 113 Cedar Street, Milford, MA USA • Tel: 508-473-9901 • Fax: 508-473-0715

www.ProcessSensorsIR.com • irtemp@processsensors.com

